



15" Touchscreen HMI with IIoT Features



- Class I, Division 2 Rated
- Dual Ethernet Ports
- Built-in Edge Gateway Function
- Enhanced Graphics & Security
- Email Alarm Notification and Recipe Functionality
- PDF Reader



System	CPU	Quad-Core RISC
	Memory (RAM)	1 GB
	Memory (Flash)	4 GB
	RTC	Built-in
I/O Ports	Serial	1 x DE9P COM1: RS-232, COM3: RS-232* 1 x DE9S COM1: RS-485 2 or 4 wire, COM3: RS-485 2 wires
	LAN	1 x 10/100 Base-T RJ-45, 1 x GbE RJ-45
	CANbus	N/A
	USB Host	1 x USB 2.0
	USB Client	N/A
	Audio	1 x audio line out – 3.5 mm and built-in mono speaker
	Video	N/A
	Wi-Fi	N/A
	HDMI®	N/A
	SD Card Slot	1 x Secure Digital (SD/SDHC) Memory Card Socket, up to 32 GB
	Display	Display Type
Size (W x H)		12.00 x 9.00 inches [304.7 x 228.5 mm]
Max. Resolution		1024 x 768
Max. Colors		16.2 M
Luminance (cd/m ²)		350
View Angle (H°/V°)		176/176
Contrast Ratio		2500:1
Backlight Lifetime (Hours)		70,000+
Touch Screen	Type	4-wire resistive touch
	Active Area Accuracy	Length (X) ±2%, width (Y) ±2%
Electrical	Input Voltage	24 ± 20% VDC
	Input Current	1.3 A @ 24 VDC
	Input Power	31.2 W
	Power Isolation	Built-in
	Isolation Resistance	Exceed 50 MΩ at 500 VDC
Mechanical	Enclosure	Aluminum, Charcoal Grey
	PCB Coating	Yes
	Dimensions (W x H x D)	14.41 x 11.54 x 1.90 inches [366 x 293 x 48.2 mm]
	Cutout Dimensions (W x H)	13.86 x 10.98 inches [352 x 279 mm]
	Net Weight	Approx. 6.04 lbs. [2.74 kg]
Environmental	Mounting	Panel mounting, VESA 75 x 75 mm
	Operating Temperature	32° ~ 122°F [0° ~ 50°C]
	Storage Temperature	-4° ~ 140°F [-20° ~ 60°C]
	Relative Humidity	10% ~ 90% (non-condensing)
	Altitude (Air Pressure)	Below 3,000 meters (70.1kPa)
	Vibration Endurance	10 to 25 Hz (X, Y, Z direction, 2G, 30 minutes)
	Rating	UL Type 4X (indoor use only), NEMA 4, IP66 compliant front panel
	Certifications	cULus (Class I, Div 2 rated), CE, RoHS
Software	EBPro (v6.08.01 or later), EasyAccess 2.0 (optional), CODESYS (optional), IIoT Ready, MQTT, Sparkplug B, VNC, CMTViewer, WebView	
Notes	*Only Tx & Rx (no RTS/CTS) may be used for COM1 RS-232 when COM3 RS-232 is also used CODESYS® is a trademark of CODESYS GmbH Specifications subject to change without notice	

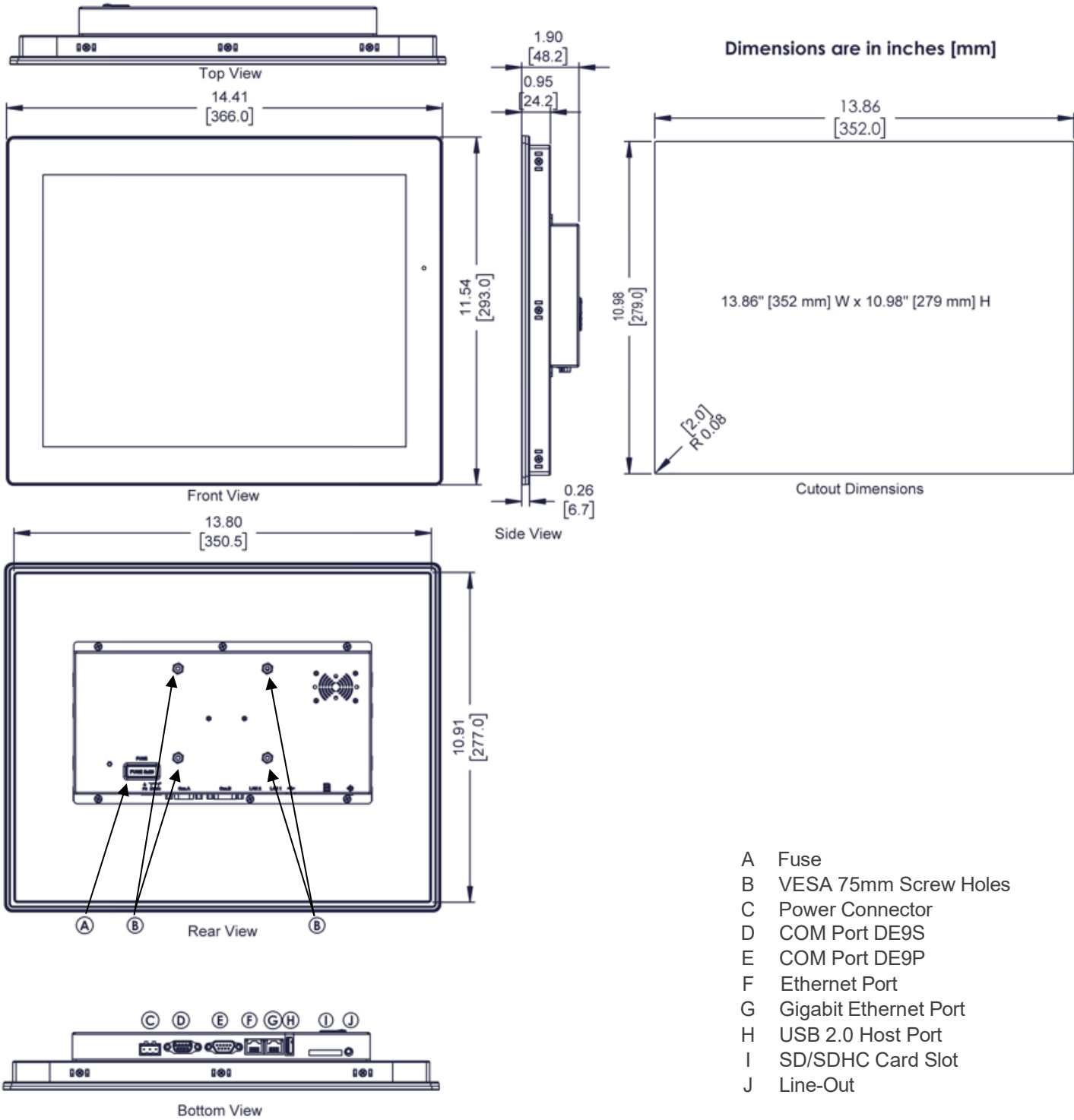

- A Fuse
- B VESA 75mm Screw Holes
- C Power Connector
- D COM Port DE9S
- E COM Port DE9P
- F Ethernet Port
- G Gigabit Ethernet Port
- H USB 2.0 Host Port
- I SD/SDHC Card Slot
- J Line-Out

Why Buy A Maple HMI

In addition to our powerful and affordable hardware, we'll also continue to support your company long after a sale. Wide product selection, large in-stock inventory, outstanding product warranty, free technical support and software, and in-house repairs with quick turnaround times, Maple Systems has your business covered.



Add Remote IO for PLC Functionality

Select Maple Advanced and High-Performance HMIs have a sleek hardware platform that runs both an HMI application created with our free HMI software and PLC logic programmed with CODESYS; each on its own dedicated processor. Unlike the typical multicore set up, where the operating system scheduler is responsible for allocating tasks to each processor, these HMIs have a hard separation between cores. One core is dedicated to the HMI application, the other to executing PLC logic of the CODESYS project. This ensures taxing graphics processing operations will not interfere with deterministic real time control tasks executing on the other processor.

After selecting your HMI, choose from a suite of easy to use [powerful I/O modules](#) to connect to your field equipment. We offer a complete set of I/O modules which can be combined with one of our communication couplers to create a remote I/O block.

Remote Access and the IIoT

[Remote access](#) is the ability to access an HMI or connected device, from another device, at any time, and from anywhere. With our [free HMI software](#) and supported hardware solutions, you have the freedom to access the HMI, and all its data and applications, from another device and control it as if you were standing in front of it. Our Advanced and High-Performance HMIs support [cMT Viewer](#), [WebView](#), Web Streaming, and [EasyAccess 2.0](#) and are designed to make accessing your HMI and data fast and streamlined.

Let us serve as your guide, making it an easy process to join the next evolution of automated control. Our Advanced and High-Performance HMIs can act as an access point enabling operating equipment on the plant floor to connect to information technologies of the Industrial Internet of Things (IIoT). With our IIoT solutions, that are already included in the EBPro software, we can help you achieve better access to invaluable data and open a world of possibilities for your business. Read more about our [IIoT solutions](#).

Build your SCADA

We offer all the components you need to create your own unique level of supervisory data acquisition and control, from the simplest stand-alone machine to sophisticated multi-device networked production line(s), all the way to enterprise-level operations and IIoT functionalities leveraging cloud connectivity.

Our products can help you standardize communications between devices, gluing different systems together for one source to your SCADA. No need to redesign your entire application. Keep the components that are already working for you, just add Maple Systems components to grow your abilities to supervise, control, and acquire data.

Incredible Functionality Out of the Box

- Easily and quickly create the project with functional objects including numeric object, lamp object, combo-button, alarms, and recipes
- Pick and place objects, pictures, and shapes
- Import/export recipes
- Create trend display, graphs, XY plots, and pie charts
- Add passwords and security levels
- Assign communication (PLC) drivers easily and more with our Free HMI software

Additionally our HMIs support remote access solutions with VNC, MQTT, and OPC UA. For additional features see our High-Performance HMI series.



User Friendly HMI Configuration Software

Because designing the layout of screens and user-interface (UI) of the HMI is typically where most of the development time is spent, we've made our Free HMI configuration software easy to use.

- Import tags feature
- Tools to diagnose and monitor PLC to HMI connection
- Debugging tools
- Pre-built libraries
- Off-line and on-line simulation

These are just a few of the ways our software makes creating your project easier. We also have controller information sheets, cable drawings, sample projects, Getting Started Guides, and videos/tutorials available in our [support center](#) 24/7.



Programmable Logic Controller (PLC) Connectivity

With over 300 PLC & Controller communication protocols, these HMIs will easily integrate with your preferred PLC brands, including:

Allen-Bradley
Siemens
Omron
Emerson
GE
Panasonic
Mitsubishi
[...and many more](#)

Allen-Bradley **ABB** babcock™

BALDOR *Danfoss* SIEMENS

MITSUBISHI *Parker*

TOSHIBA YASKAWA **Koyo**

Matsushita

Panel Mount HMI Feature Overview

With few exceptions, all our Standard HMIs support (this covers all the HMI prefix models, ex: HMI5043L/LB, HMI5070L/LB):	With few exceptions, all our Advanced HMIs support (this covers all the cMT2xxx series):	With few exceptions, all our High Performance HMIs support (this covers all the cMT3xxx series HMIs):
Alarm & Event Messages	Alarm & Event Messages	Alarm & Event Messages
Animation - Flow Block	Animation - Flow Block	Animation - Flow Block
ASCII Characters	ASCII Characters	ASCII Characters
Bar Graphs	Bar Graphs	Bar Graphs
Combo Button	Combo Button	Combo Button
Data Logging and Sampling	Data Logging and Sampling	Data Logging and Sampling
Date / Time	Date / Time	Date / Time
Dynamic Drawing	Dynamic Drawing	Dynamic Drawing
Dynamic Scale	Dynamic Scale	Dynamic Scale
EasyAccess 2.0	EasyAccess 2.0	EasyAccess 2.0
EasyWatch	EasyWatch	EasyWatch
Enhanced Security Mode	Enhanced Security Mode	Enhanced Security Mode
Event Alarm Log	Event Alarm Log	Event Alarm Log
File Browser	File Browser	File Browser
Grid Display	Grid Display	Grid Display
Languages (Up to 24)	Languages (Up to 24)	Languages (Up to 24)
Libraries	Libraries	Libraries
Macros	Macros	Macros
Meters & Gauges	Meters & Gauges	Meters & Gauges
Modbus	Modbus	Modbus
Objects (Grouping, Layering, Aligning, Flip)	Objects (Grouping, Layering, Aligning, Flip)	Objects (Grouping, Layering, Aligning, Flip)
Off-line / On-line Simulation	Off-line / On-line Simulation	Off-line / On-line Simulation
OPC UA Client	OPC UA Client	OPC UA Client
Operation Log	Operation Log	Operation Log
Pass-Through Mode	Pass-Through Mode	Pass-Through Mode
Picture Object	Picture Object	Picture Object
Picture Viewer	Picture Viewer	Picture Viewer
Pie Chart	Pie Chart	Pie Chart
PLC Tag Embedded in Project	PLC Tag Embedded in Project	PLC Tag Embedded in Project
Project Password	Project Password	Project Password
Recipes	Recipes	Recipes
Remote Access	Remote Access	Remote Access
Scheduler	Scheduler	Scheduler
Security Levels (Enhanced)	Security Levels (Enhanced)	Security Levels (Enhanced)
System Setting Editor	System Setting Editor	System Setting Editor
Table	Table	Table
Text Object	Text Object	Text Object
Timer Object	Timer Object	Timer Object
Trend Display (Graphs)	Trend Display (Graphs)	Trend Display (Graphs)
User-Defined Start-Up Screen	User-Defined Start-Up Screen	User-Defined Start-Up Screen
Utility Manager	Utility Manager	Utility Manager
VNC Server	VNC Server	VNC Server
XY Plot	XY Plot	XY Plot
Email (1)	Email	Email
Macro Windows Open / Cycle / Close (1)	Macro Windows Open / Cycle / Close	Macro Windows Open / Cycle / Close
MQTT (1)	MQTT	MQTT
String Table (1)	String Table	String Table
Time Synchronization (1)	Time Synchronization	Time Synchronization
USB Tethering	USB Tethering	USB Tethering
VNC Viewer (1)	VNC Viewer	VNC Viewer
	IP Camera	IP Camera
	USB Camera	USB Camera
	Animation (Objects, Word Lamp, GIFs, Moving Shape)	Animation (Objects, Word Lamp, GIFs, Moving Shape)
	BACnet	BACnet
	CANbus	CANbus
	cMT Diagnoser	cMT Diagnoser
	cMT Viewer Support	cMT Viewer Support
	CODESYS (2)	CODESYS
	Media Player	Media Player
	MQTT - Advanced JSON	MQTT - Advanced JSON
	MQTT - AWS IoT, Sparkplug B, Azure IoT Hub	MQTT - AWS IoT, Sparkplug B, Azure IoT Hub
	PDF Reader	PDF Reader
	Web Streaming	Web Streaming
	WebView	WebView
		Barcode Scanner (Android Camera)
		Database Server
		File Transfer Protocol (FTP)
		OPC UA Server
		PLC Web Browser
		SQL Database Server Integration

This table is for illustration only and subject to change. Always check the software to see if a feature is supported in your specific hardware.

(1) Not supported in the B Series (HMI5040B, 5070B, 5100B)

(2) Not supported on the cMT2166X