

# Micro-CAPP™ Quick Start Guide

**Micro-CAPP FDX**

**Micro-CAPP RTS**

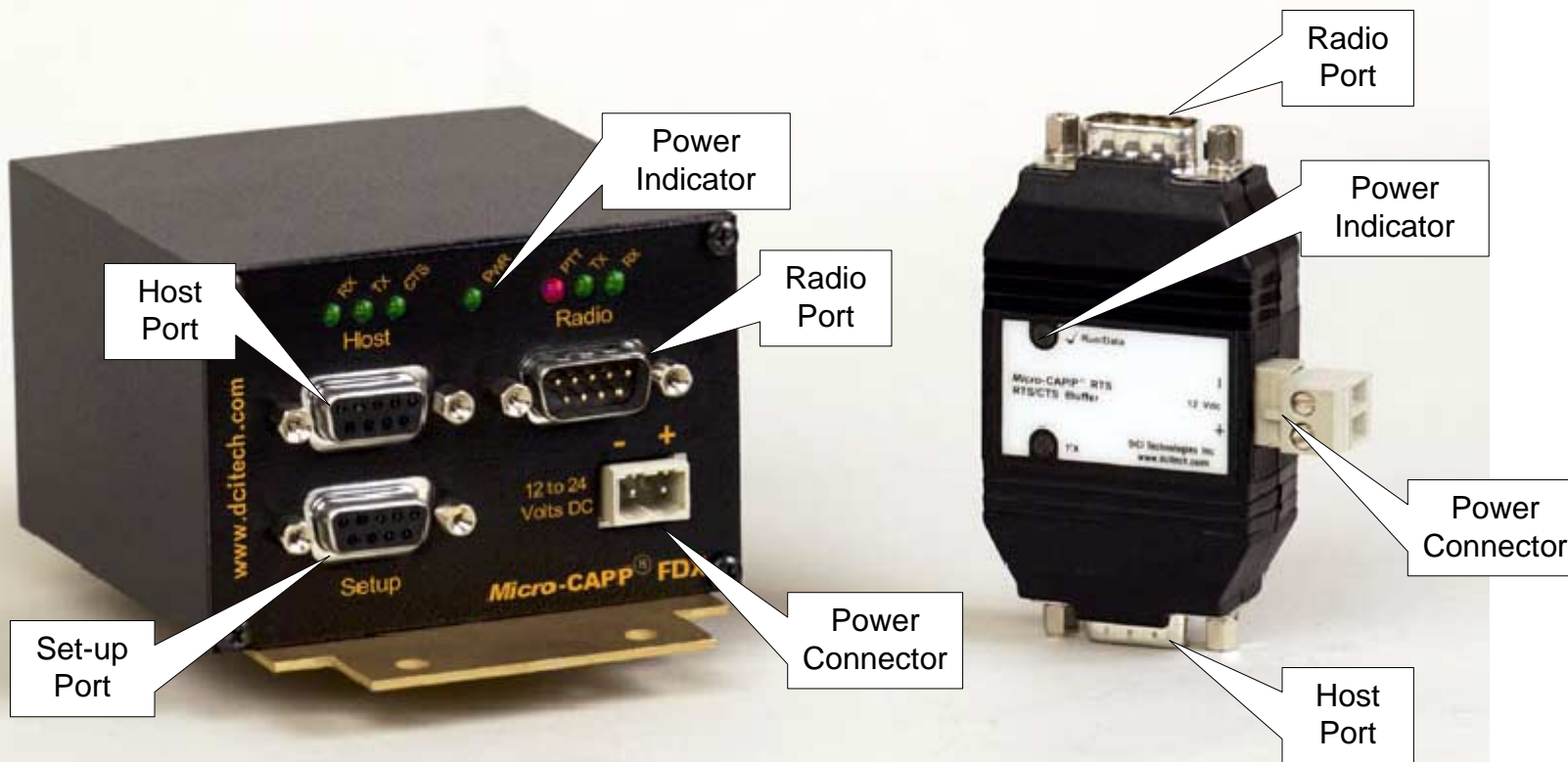

WWW.DCITECH.COM

<b>Project:</b> Micro-CAPP Documentation	
<b>Subject:</b> Quick Start Guide	
<b>Detail:</b> Connector Layouts	<b>Revision:</b> 1.4b
<b>Company:</b> DCI Technologies Inc.	<b>Designer:</b> W.E.(Ted) Skinner
<b>Filename:</b> Micro-CAPP QS Ver1_4b.vsd	<b>Date:</b> May 19, 2003 09:37

This is a conceptual drawing provided as a courtesy only. It is not to be used as an engineering drawing or to be interpreted as a final system design.

*Micro-CAPP™* Quick Start Guide  
 T96SR Buffer, Baud Rate Translation, or Repeater with Local Drop

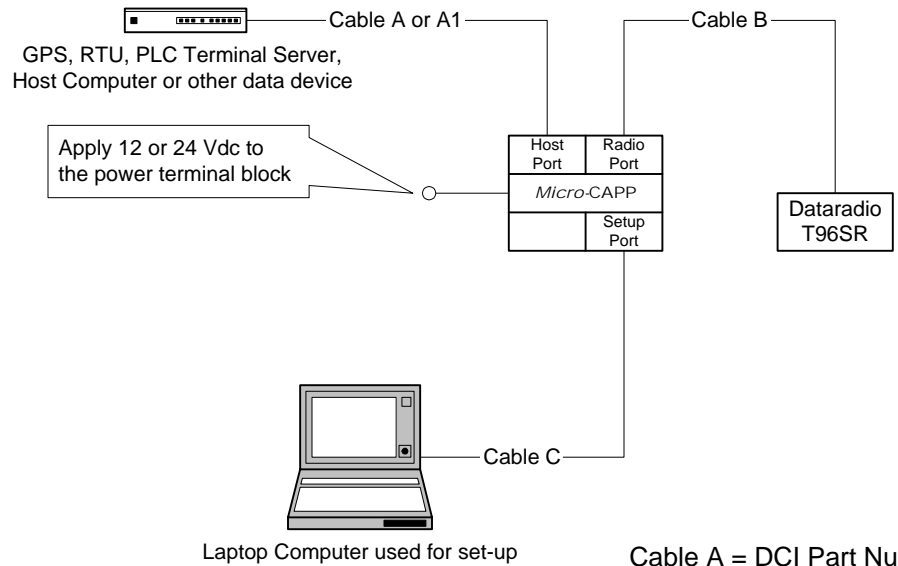

Cable A = DCI Part Number DE15-T96-CA

Cable B = Dataradio Part Number 697-0000-001 PC/Data

Cable C = DCI Part Number DB9-SU-CA

WWW.DCITECH.COM

<b>Project:</b> Micro-CAPP Documentation	
<b>Subject:</b> Quick Start Guide	
<b>Detail:</b> Buffer Overview	<b>Revision:</b> 1.4b
<b>Company:</b> DCI Technologies Inc.	<b>Designer:</b> W.E.(Ted) Skinner
<b>Filename:</b> Micro-CAPP QS Ver1_4b.vsd	<b>Date:</b> May 19, 2003 09:37

This is a conceptual drawing provided as a courtesy only. It is not to be used as an engineering drawing or to be interpreted as a final system design.

*Micro-CAPP*<sup>TM</sup> Quick Start Guide  
 Integra Store and Forward Repeater

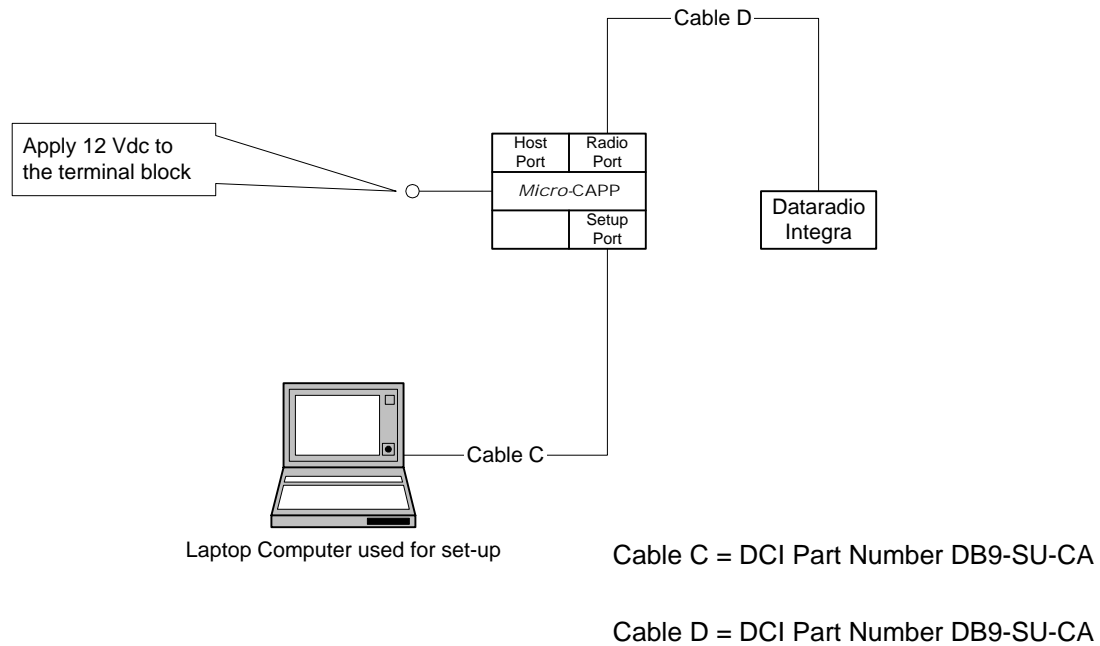

WWW.DCITECH.COM

<b>Project:</b> Micro-CAPP Documentation	
<b>Subject:</b> Quick Start Guide	
<b>Detail:</b> Store and Forward	<b>Revision:</b> 1.4b
<b>Company:</b> DCI Technologies Inc.	<b>Designer:</b> W.E.(Ted) Skinner
<b>Filename:</b> Micro-CAPP QS Ver1_4b.vsd	<b>Date:</b> May 19, 2003 09:37

Micro-CAPP™ Quick Start Guide  
Typical Application

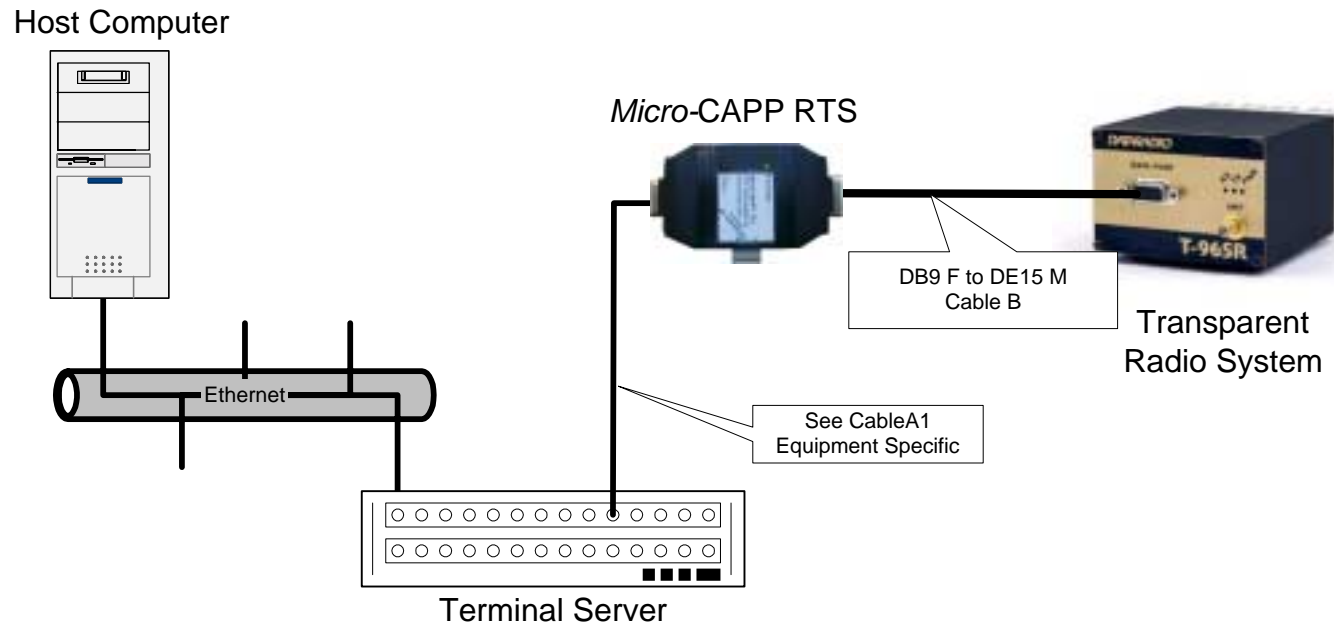

WWW.DCITECH.COM

<b>Project:</b> Micro-CAPP Documentation	
<b>Subject:</b> Quick Start Guide	
<b>Detail:</b> Typical RTS Application	<b>Revision:</b> 1.4b
<b>Company:</b> DCI Technologies Inc.	<b>Designer:</b> W.E.(Ted) Skinner
<b>Filename:</b> Micro-CAPP QS Ver1_4b.vsd	<b>Date:</b> May 19, 2003 09:37

This is a conceptual drawing provided as a courtesy only. It is not to be used as an engineering drawing or to be interpreted as a final system design.

*Micro-CAPP™* Quick Start Guide  
DL3282 (Bell 202) Modem/Analog Radio Interface

Host Computer

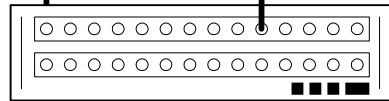
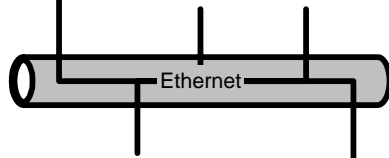
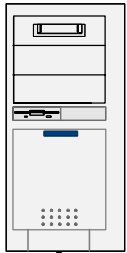

Terminal Server

*Micro-CAPP RTS or  
Micro-CAPP FDX*



DB9 F to DB25 M  
Cable M2

See CableA1  
Equipment Specific

Dataradio DL-3282 Bell 202 Modem



Analog Radio



Dataradio Cable  
023-3410-125 for DL-3400 Radio  
or  
023-3410-109 for other Analog Radio's

WWW.DCITECH.COM

<b>Project:</b> Micro-CAPP Documentation	
<b>Subject:</b> Quick Start Guide	
<b>Detail:</b> DL-3282 Interface	<b>Revision:</b> 1.4b
<b>Company:</b> DCI Technologies Inc.	<b>Designer:</b> W.E.(Ted) Skinner
<b>Filename:</b> Micro-CAPP QS Ver1_4b.vsd	<b>Date:</b> May 19, 2003 09:37

This is a conceptual drawing provided as a courtesy only. It is not to be used as an engineering drawing or to be interpreted as a final system design.

*Micro-CAPP™* Quick Start Guide  
 Dataradio Integra-TR to Dataradio Integra-H Back to Back Interface

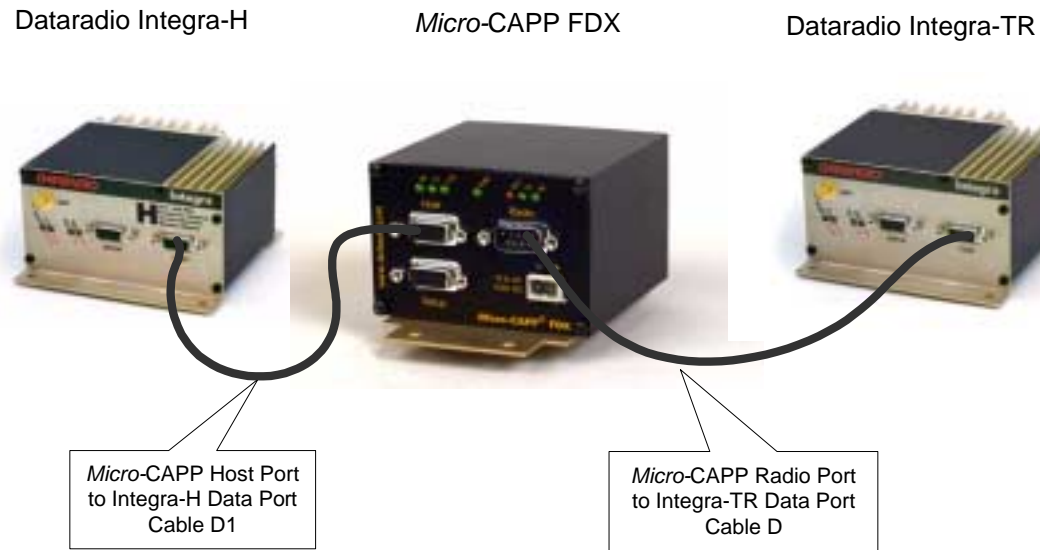

WWW.DCITECH.COM

<b>Project:</b> Micro-CAPP Documentation	
<b>Subject:</b> Quick Start Guide	
<b>Detail:</b> Back to Back Integras	<b>Revision:</b> 1.4b
<b>Company:</b> DCI Technologies Inc.	<b>Designer:</b> W.E.(Ted) Skinner
<b>Filename:</b> Micro-CAPP QS Ver1_4b.vsd	<b>Date:</b> May 19, 2003 09:37

This is a conceptual drawing provided as a courtesy only. It is not to be used as an engineering drawing or to be interpreted as a final system design.

*Micro-CAPP™* Quick Start Guide  
Dataradio Integra to MDS Back to Back Interface

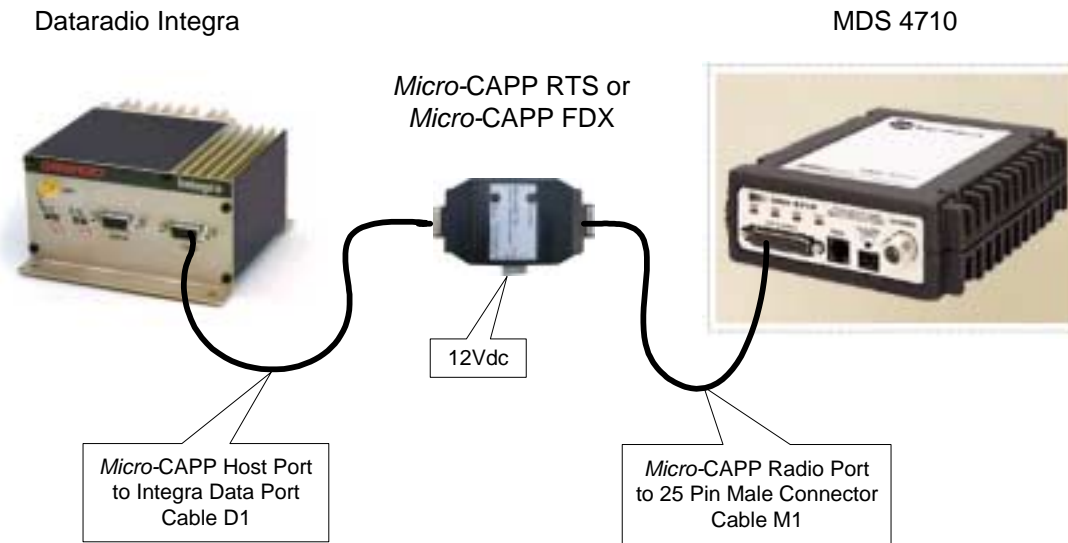

WWW.DCITECH.COM

<b>Project:</b>	Micro-CAPP Documentation	
<b>Subject:</b>	Quick Start Guide	
<b>Detail:</b>	Integra-MDS Interface	<b>Revision:</b> 1.4b
<b>Company:</b>	DCI Technologies Inc.	<b>Designer:</b> W.E.(Ted) Skinner
<b>Filename:</b>	Micro-CAPP QS Ver1_4b.vsd	<b>Date:</b> May 19, 2003 09:37

This is a conceptual drawing provided as a courtesy only. It is not to be used as an engineering drawing or to be interpreted as a final system design.

## Standard Interface Cable Guide

**Computer to *Micro-CAPP* Host Port (CABLE A)**

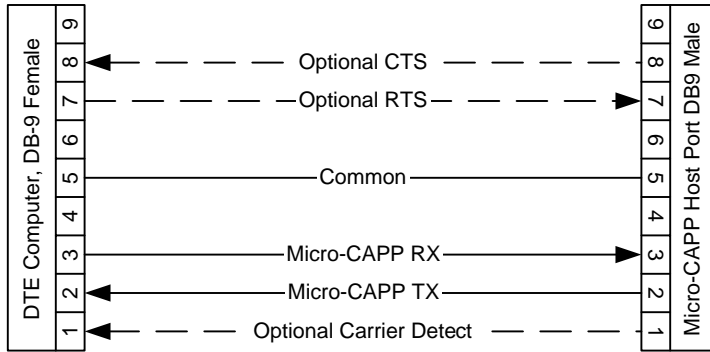

***Micro-CAPP* Radio Port to Dataradio T96SR , With Power (CABLE B)**

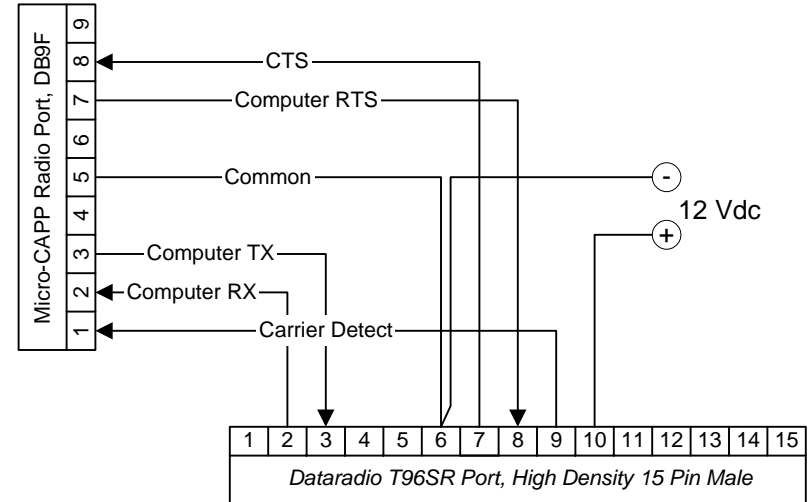

***Micro-CAPP* Set-up Port to Computer (CABLE C)**

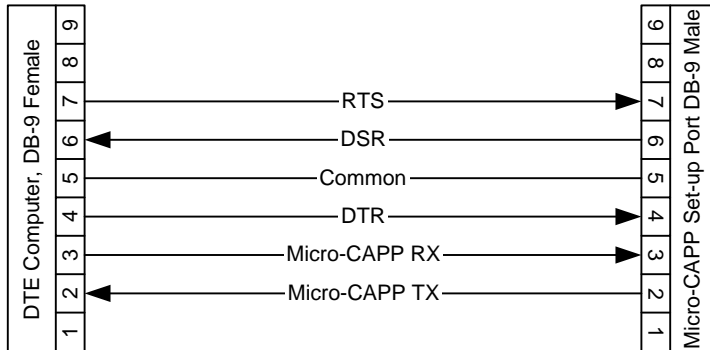

***Micro-CAPP* Radio Port to Integra (CABLE D)**

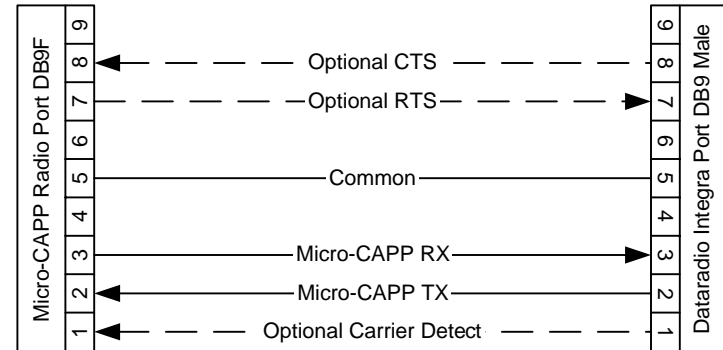

WWW.DCITECH.COM

<b>Project:</b> Micro-CAPP Documentation	
<b>Subject:</b> Quick Start Guide	
<b>Detail:</b> Cable Details	<b>Revision:</b> 1.4b
<b>Company:</b> DCI Technologies Inc.	<b>Designer:</b> W.E.(Ted) Skinner
<b>Filename:</b> Micro-CAPP QS Ver1_4b.vsd	<b>Date:</b> May 19, 2003 09:37

# Custom Interface Cable Guide

Pigtail Cable to Micro-CAPP Host Port (CABLE A1)

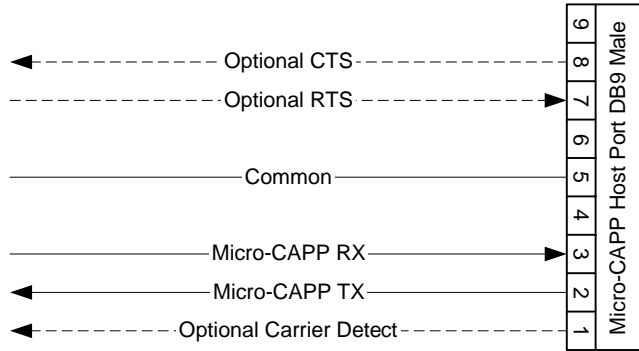

Micro-CAPP RTS or FDX to Dataradio Integra (CABLE D1)

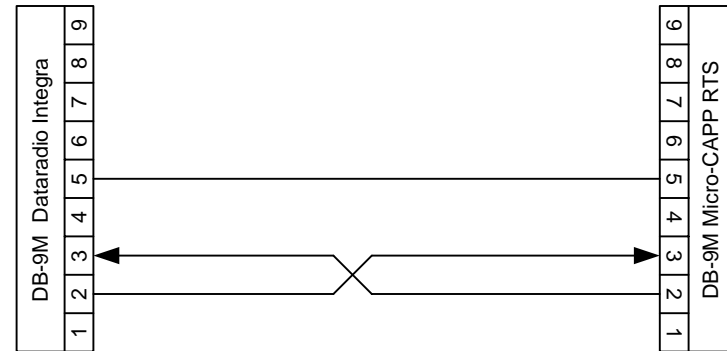

Micro-CAPP RTS or FDX to MDS 4710 (CABLE M1)

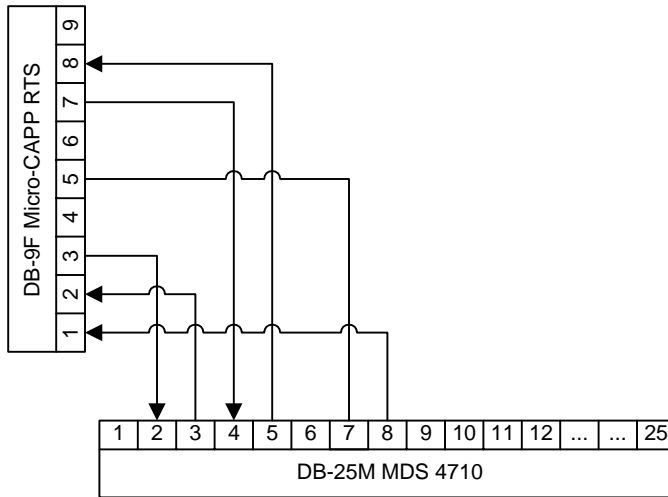

Micro-CAPP RTS or FDX to Dataradio DL-3282 Modem (CABLE M2)

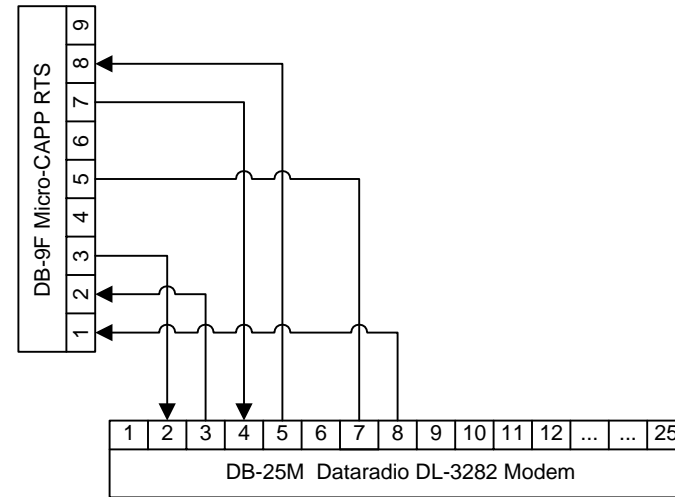

WWW.DCITECH.COM

<b>Project:</b> Micro-CAPP Documentation	
<b>Subject:</b> Quick Start Guide	
<b>Detail:</b> Custom Cables	<b>Revision:</b> 1.4b
<b>Company:</b> DCI Technologies Inc.	<b>Designer:</b> W.E.(Ted) Skinner
<b>Filename:</b> Micro-CAPP QS Ver1_4b.vsd	<b>Date:</b> May 19, 2003 09:37

This is a conceptual drawing provided as a courtesy only. It is not to be used as an engineering drawing or to be interpreted as a final system design.

## Micro-CAPP Feature Comparison

### Hardware:

<i>Micro-CAPP® FDX</i>	<i>Micro-CAPP® RTS</i>
Dual Flash Based RISC Processors	Single Flash Based RISC Processor
Dual High speed FIFO's up to 64K bytes	128 byte FIFO
Rugged Aluminum Enclosure	Small case that can be inserted in-line in a cable
10 to 30 Vdc operation	10 to 30 Vdc operation

### Features:

	<i>Micro-CAPP® FDX</i>	<i>Micro-CAPP® RTS</i>
Highly accurate RTS/CTS radio control	<input checked="" type="checkbox"/>	<input checked="" type="checkbox"/>
Enables "Data Only" serial devices to use a wireless modem	<input checked="" type="checkbox"/>	<input checked="" type="checkbox"/>
Handles binary data (protocol independent)	<input checked="" type="checkbox"/>	<input checked="" type="checkbox"/>
Flash Processor, field upgradeable	<input checked="" type="checkbox"/>	<input checked="" type="checkbox"/>
CDMA Capable (Hold off Data TX if CD is On)	<input checked="" type="checkbox"/>	<input checked="" type="checkbox"/>
Custom Application Development Available	<input checked="" type="checkbox"/>	<input checked="" type="checkbox"/>
Windows Software for Configuration	<input checked="" type="checkbox"/>	<input type="checkbox"/>
Externally Accessible DIP Switch Configuration	<input type="checkbox"/>	<input checked="" type="checkbox"/>
Baud Rate Translation	<input checked="" type="checkbox"/>	<input type="checkbox"/>
Store and Forward Repeater Option (Parrot)	<input checked="" type="checkbox"/>	<input type="checkbox"/>

## Micro-CAPP FDX Connector Pinouts

Notation:

Output - Refers to an RS-232 Output

Input - Refers to an RS-232 Input

N/C - Indicates pin not connected

### Host Port, DCE 9 Pin Female Connector

Pin	Name	Direction	Function
1	DCD	Output	Asserted when Micro-CAPP is sending Data out Pin 2
2	RXD	Output	Data from Micro-CAPP sent out the port
3	TXD	Input	Data given to the Micro-CAPP to be passed on the Radio Port
4	DTR	Input	N/C
5	GND		Electrical Common
6	DSR	Output	N/C
7	RTS	Input	Ignored
8	CTS	Output	Used for flow control
9	RI	Output	N/C

### Radio Port, DTE 9 Pin Male Connector

Pin	Name	Direction	Function
1	DCD	Input	Carrier Detect Signal from Radio Indicating Channel is Busy
2	RXD	Input	Data Received from the Radio
3	TXD	Output	Data sent from the Micro-CAPP to the Radio to be Transmitted
4	DTR	Output	Ignored
5	GND		Electrical Common
6	DSR	Input	Ignored
7	RTS	Output	Used as a Begin Transmission Signal
8	CTS	Input	Used for flow control or RTS handshaking
9	RI	Input	N/C

### Set-Up Port, DCE 9 Pin Female Connector

Pin	Name	Direction	Function
1	DCD	Output	N/C
2	TXD	Output	Data from Micro-CAPP sent out the port
3	RXD	Input	Data given to the Micro-CAPP command processor to be processed
4	DTR	Input	Signal from Set-up Computer used to re-boot Micro-CAPP
5	GND		Electrical Common
6	DSR	Output	Directly connected to Pin 7, used for Cable Integrity Feedback
7	RTS	Input	Signal from Set-up Computer used to Check Cable integrity
8	CTS	Output	N/C
9	RI	Output	N/C

## Micro-CAPP RTS Connector Pinouts

### Notation:

Output - Refers to an RS-232 Output

Input - Refers to an RS-232 Input

N/C - Indicates pin not connected

### Host Port, DCE 9 Pin Female Connector

Pin	Name	Direction	Function
1	DCD	Output	Direct to Pin 1 of Radio Port
2	RXD	Output	Direct to Pin 2 of Radio Port
3	TXD	Input	Data given to the Micro-CAPP to be passed on the Radio Port
4	DTR	Input	N/C
5	GND		Electrical Common
6	DSR	Output	N/C
7	RTS	Input	Ignored
8	CTS	Output	Ignored
9	RI	Output	N/C

### Radio Port, DTE 9 Pin Male Connector

Pin	Name	Direction	Function
1	DCD	Input	Carrier Detect Signal from Radio Indicating Channel is Busy
2	RXD	Input	Data Received from the Radio
3	TXD	Output	Data sent from the Micro-CAPP to the Radio to be Transmitted
4	DTR	Output	Ignored
5	GND		Electrical Common
6	DSR	Input	Ignored
7	RTS	Output	Used as a Begin Transmission Signal
8	CTS	Input	Used for flow control via RTS handshaking
9	RI	Input	Ignored

## Micro-CAPP Specifications

<b>Micro-CAPP FDX</b>	<b>Host Port</b>	<b>Radio Port</b>
Baud Rate	1200, 2400, 4800, 9600, 19,200	1200, 2400, 4800, 9600, 19,200
Data Format	8 Bit or 9 Bit	8 Bit or 9 Bit
Character Pacing	0 to 65 ms in 0.001 ms increments	0 to 65 ms in 0.001 ms increments
Rate Padding	0 to 65 seconds in 1 ms increments	0 to 65 seconds in 1 ms increments
Pre-Transmit	N/A	0 to 65 seconds in 1 ms increments
Post-Transmit	N/A	0 to 65 seconds in 1 ms increments
CTS Control	Ignore, Force On, Drop when Buffer ½ full	Ignore, Wait for CTS or define time
Port Connector	Standard DB-9 Socket (Female)	Standard DB-9 Pin (Male)
I/O Compatibility	EIA RS-232	EIA RS-232

<b>Micro-CAPP RTS</b>	<b>Host Port</b>	<b>Radio Port</b>
Baud Rate	1200, 4800, 9600, 19,200	Must Match Host Port
Data Format	8 Bit or 9 Bit	Must Match Host Port
Character Pacing	None	None
Rate Padding	None	None
Pre-Transmit	N/A	2 characters times after CTS has been received from Radio
Post-Transmit	N/A	3.5 character times after last character has been transmitted
CTS Control	N/A	Wait for CTS
Port Connector	Standard DB-9 Socket (Female)	Standard DB-9 Pin (Male)
I/O Compatibility	EIA RS-232	EIA RS-232

1. *What data formats can the Micro-CAPP handle?*

The *Micro-CAPP* is an asynchronous serial device that will transparently pass 8 or 9 data bits, 1 start bit and 1 stop bit at rate from 1200 Baud to 19,200 Baud. What this means is that any data format that has a combined total of the 10 or 11 bits will pass thru ok. For example 7 bits, even or odd parity and 1 stop has the same bit count hence it will pass ok.

2. *Can I use a Micro-CAPP to interface between two types of Radio Modems?*

Yes. The two ports on the *Micro-CAPP* buffer are set-up independently for baud rate and timing. Any data that is received on one port will be transferred and transmitted out the other port, but will have its speed changed to whatever the settings are on the respective port. Also one port (Radio Port) has full RTS/CTS control so you can use the *Micro-CAPP* as a buffer to add radio control what was otherwise just a data stream. This effectively enables a standard transparent radio like the Dataradio T96SR to have DOX (data operated switch) control. This feature works very well if you want to connect a T96SR and an Integra-TR or Integra-H back to back.

3. *I have a T96SR system but I have one RTU site that needs to operate at a different baud rate than the rest of the network. Can the Micro-CAPP help with this?*

Yes. As noted in question two the two ports on the *Micro-CAPP* buffer are set-up independently for baud rate and timing. Any data that is received on one port will be transferred and transmitted out the other port, but will have its speed changed to whatever the settings are on the respective port. This will allow you to have RTU's connected at various data rates on a T96SR transparent radio system.

4. *What protocols with the Micro-CAPP Handle?*

The *Micro-CAPP* can operate in one of two modes, Buffer and Parrot, each has some considerations when it comes to protocols.

The buffer mode is completely protocol transparent, but it can change the character timing. By setting the Inter-Character delay time and Rate Padding parameters you can determine exactly how you want to pace data out of the buffer. Some protocols such as the GE Fanuc SNP that require specific time gaps within the messages may be affected. Modbus ASCII or RTU if fine

The store and forward "Parrot" option in the *Micro-CAPP* is a very simple implementation. It is called a "Parrot" option because it will repeat everything it hears, hence it is protocol transparent. However because it repeats everything, both your host system and the RTU must be able to handle hearing their own transmissions reflected back to them.

5. *What about using multiple Micro-CAPP "Parrot" repeaters?*

Suppose you have a radio network with 3 links cascaded between 4 points: A --- B --- C--- D and you want to use the *Micro-CAPP* in intermediary points B and C. In a single frequency system you can have two *Micro-CAPP*s back to back (sites B and C) with Store and Forward turned on but you must enable echo suppression or you will start generating a lot of looping traffic. However this will decrease your system throughput significantly as well as multi-path signals could be problematic.

The best solution is to use a real repeater (two frequencies) at either site B or C. You can also use the *Micro-CAPP* in Buffer mode to interface between two different radio systems. For example if you have a store and forward *Micro-CAPP* located at point B you could still install a *Micro-CAPP* buffer at Point C connected to a Spread Spectrum link (such as the Integra-H) to Point D. The *Micro-CAPP* also works as a great interface between a back to back T96SR and Integra radio. Another option is to set up a submaster system at Point C that polls Point D over a different radio or frequency.

*6. Should I use a Full Duplex Repeater or a Micro-CAPP "Parrot" Store and Forward Repeater?*

As a general summary a Store and Forward Repeater should never be your first choice. Always try and implement the system with a full duplex repeater. If frequencies are not available and you have to operate on a single frequency or cost is a big issue then store and forward can be considered. If you do decide to use a store and forward repeater then the system needs to be carefully designed taking into consideration multipath signals and protocol tolerance of echoed messages.

*7. What happens if some radio sites are in range of both the host and the "Parrot" repeater?*

This is no problem if you are using Integra Radios in the system. The Integra has a setting where you can select the "Unit Type". This will allow you to set the Integra radio to two different modes, "Master" and "Remote". There is also a second parameter called "Data Delivery" and this can be set to "All" or "Selective". What you need to do is set all radios in the system to "Remote" except for the radio that is connected to the Micro-CAPP "Parrot", which needs to be set to "Master". Then set data delivery to "selective" on all radios in the system that are in range of both the "Host" and "Parrot". What this does is effectively disables communications between radios of "Like Types", hence eliminating duplicate messages arriving at sites that are within radio range of both the "host" site and the "Parrot" repeater site.

*8. Is there are speed difference between a full duplex repeater and a Store and Forward Repeater?*

Yes. As the name suggests, in a store and forward repeater all messages are stored in memory and then repeated again, hence all messages are transmitted twice. This then makes the maximum effective throughput of the system  $\frac{1}{2}$  of what it would be with a full duplex repeater system. However, if you have a system with gaps in polling that are more than twice the size of the average data message, you may experience no effective system speed reduction.

*9. Can I have a local RTU located at the same site and use the same radio as the Micro-CAPP when using the Store and Forward Repeater Option?*

Yes. You can select an option with the set-up software to enable "Local Drop" when in "Parrot" mode. This causes all repeated messages to be sent out the Host Port in addition to being sent back out to the radio port for re-transmission. Keep in mind that the Micro-CAPP will repeat all messages even if the message is destined for the local RTU. For some protocols you may need to set-up your local RTU to delay it's reply to enable a message gap to occur. Under some conditions the RTU Reply may get stacked in the buffer immediately behind the repeated message.

For more information you can contact:  
DCI Technologies Inc.  
PO Box 11, Site 12, RR 5  
Calgary, AB T2P 2G6  
Canada

Ph: 403.720.4885  
FX: 403 720.3905

Email: [connected@dcitech.com](mailto:connected@dcitech.com)

WEB: <http://www.dcitech.com>