

# Matrix Orbital Corporation

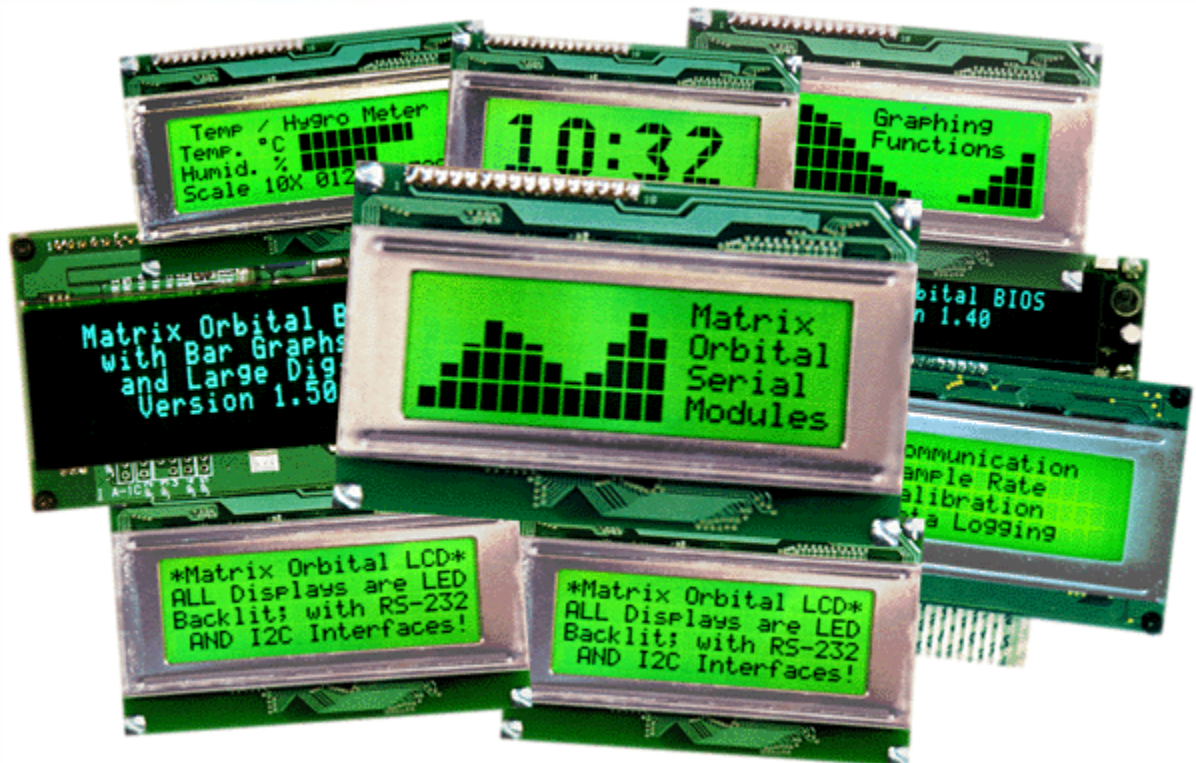

## LK204-25

### User Manual



**Important: Read page 2 before applying power.**

## Connecting LK204-25

### Regular Voltage

Power is applied to the white or brown four pin SIP connector as follows:

- Pin 1: +5Vdc
- Pin 2: = SCL (I<sup>2</sup>C clock)
- Pin 3: = SDA (I<sup>2</sup>C data)
- Pin 4: Gnd

If the sole data source is via the RS-232, the data input is via the DB9 connector. Pins 2 and 3 are not used.

### Wide Voltage Option (V)

Power is applied to the white or brown four pin SIP connector as follows:

- Pin 1: +7 - +15Vdc
- Pin 2: = SCL (I<sup>2</sup>C clock)
- Pin 3: = SDA (I<sup>2</sup>C data)
- Pin 4: Gnd

If the sole data source is via the RS-232, the data input is via the DB9 connector. Pins 2 and 3 are not used

### Wide Voltage Option (VPT)

Power is applied to the white or brown four pin SIP connector as follows:

- Pin 1: +8 - +30Vdc
- Pin 2: = SCL (I<sup>2</sup>C clock)
- Pin 3: = SDA (I<sup>2</sup>C data)
- Pin 4: Gnd

If the sole data source is via the RS-232, the data input is via the DB9 connector. Pins 2 and 3 are not used

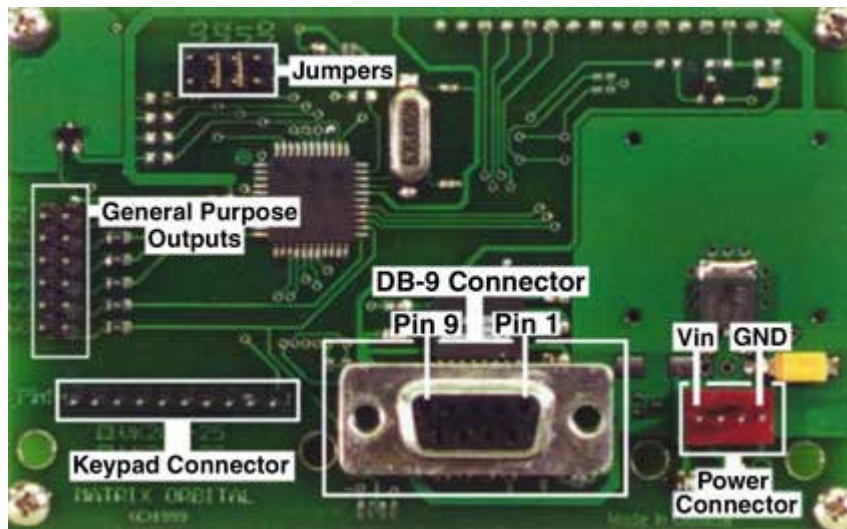

**WARNING:**

**DO NOT APPLY ANY POWER WITH A REVERSED CABLE.**

**DO NOT APPLY AN VOLTAGE OTHER THAN THE SPECIFIED VOLTAGE.**

**DO NOT USE ANY CABLES OTHER THAN THE CABLES SUPPLIED BY MATRIX ORBITAL, UNLESS YOU ARE AWARE OF THE MODIFICATIONS REQUIRED.**

**DO NOT UNDER ANY CIRCUMSTANCES USE AN UNMODIFIED FLOPPY DRIVE POWER CABLE.**

**DB9 Connector Pin Out**

RS - 232 port: This connector is wired so that a standard “straight through” 9 pin D-sub cable may be used to connect the modules on a standard serial port such as comm ports on PCs. Note that this device complies to the EIA232 standard in that it uses signal levels from +/- 3V to +/- 12V. It will not operate correctly at TTL (0 to + 5V) levels.

Pin Number	Description
2	Data Out
3	Data In
5	Ground
9	+ 5Vdc

Note: Signals are shown as interpreted by the Liquid Crystal Display module.

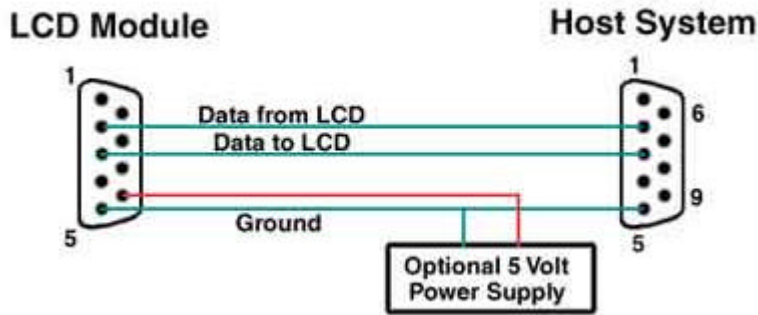

Power may be provided to the module by pin 9 of the DB9 connector instead of through the 4-pin SIP. If power is to be applied using the DB9, it must be a regulated 5Vdc supply. If the user intends to use pin 9 as the power source, the user must solder the 5 volt jumper point beside the DB9 connector. If you have any further questions or concerns don't hesitate to contact Matrix Orbital at support@matrix-orbital.com.

**Warning: Use this method of power up at your own risk. Application of a voltage to pin 9 greater than 5.5volts will cause immediate destruction of unit and void the warranty.**

Note: This applies to wide voltage units (V and VPT extensions) as well as to standard 5 volt units.

**General Purpose Output (GPO)**

Each of the GPO's are meant to be used as a pair. The positive side of the GPO's are connected to a power source of + 5Vdc supplied by the module at 20mA. The negative side of the GPO's are capable of finding a path to ground through a 240 ohm resistor. This resistor will limit the current flow through a GPO to approximately 20mA in the event of a short circuit. If the device which is being driven by a GPO requires a relatively high current (such as a relay) and has an internal resistance of it's own greater than 250 ohms, then the 240 ohm resistor may be shorted. You will find this resistor directly below the negative pin of the general purpose output.

Note: This operation requires soldering. The GPO's do not have any over current or over/under voltage protection so care must be taken if the user decides to connect the negative side differently. For instance if the external device is a relay it must be fully clamped to absorb any generated back electromotive force (EMF).

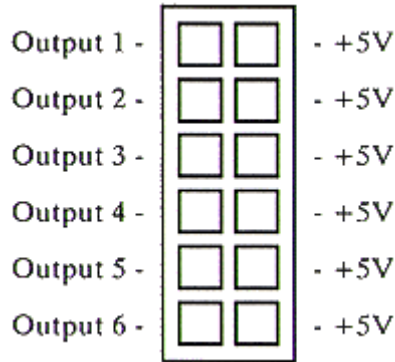

### Configuring LK204-25

Default configuration is J1 and J2 installed. This configures the RS-232 to 19 200 baud and I<sup>2</sup>C to slave address 0x5C - depending on which connector is used. Please refer to the Appendix of this manual for programming notes.

- RS-232 port: J0, J1, J2 - control baud rate
- RS-232 format is 8N1 (8 characters, no parity, one stop bit)
- I<sup>2</sup>C port: J0, J1, J2, J3 - sets slave peripheral address

Baud Rate	Slave Address	J3	J2	J1	J0
1200	50H	Off	Off	Off	Off
	52H	Off	Off	Off	On
2400	54H	Off	Off	On	Off
	56H	Off	Off	On	On
9600	58H	Off	On	Off	Off
	5AH	Off	On	Off	On
19200	5CH	Off	On	On	Off
	5EH	Off	On	On	On
1200	60H	On	Off	Off	Off
	62H	On	Off	Off	On
2400	64H	On	Off	On	Off
	66H	On	Off	On	On
9600	68H	On	On	Off	Off
	6AH	On	On	Off	On
19200	6CH	On	On	On	Off
	6EH	On	On	On	On

## The Keypad Interface

### Keypad Interface via I<sup>2</sup>C

The keypad is read by I<sup>2</sup>C master read. In short, this means that a read of the module will always return the first unread key press. A read is initiated by writing to the module with its base address plus 1, then clocking the module's return byte after the module releases the SDA line. Much more detail on this basic I<sup>2</sup>C function can be found in the I<sup>2</sup>C specification by Philips.

The module contains a ten key press buffer so that it can be polled for key presses at an infrequent rate (every 500 to 1000 mS is typical). All returned key presses indicate the presence or absence of additional logged key presses by the most significant bit (MSB - bit 7). If the user has pressed two keys since the last poll of the keypad interface, the first read will return the key code with bit 7 set and the second read will return the key code with bit 7 clear. The application must take into account this bit to keep up with user key presses. If there are no keypresses detected, the module will return zero (0x00).

### Keypad Interface via RS - 232

By default on any press of a key, the module will immediately send out the key code at the selected baud rate.

#### Auto Transmit:

If the auto transmit mode is on (default) then on any keypress, the module will immediately send out the key code at the selected baud rate. If auto transmit is off, when the poll command is sent, the module will immediately send the key code.

### Keypad Interface (Both I<sup>2</sup>C and RS - 232)

#### Auto Repeat:

Two Modes of auto repeat are available and are set via the same command.

1) Resend Key Code: This mode is similar to the action of a keyboard on a PC and is set via the '~' command with a value of 0 as outlined in the Command Set section of this manual. In this mode, when a key is held down, the key code is transmitted immediately followed by a 1/2 second delay. After this delay, key codes will be sent via the RS - 232 interface at a rate of about 5 codes per second. This mode has no effect if polling or if using the I<sup>2</sup>C interface.

2) Key down / Key up codes: This mode may be used when the typematic parameters of the Resend Key code mode are unacceptable or if the unit being operated in polled mode. The host system detects the press of a key and simulates an auto repeat inside the host system until the key release is detected. This mode is entered via the '~' command with a data value of (0x01). In this mode, when a key is held down, the key code is transmitted immediately and no other codes will be sent until the key is released. On the release of the key, the key release code transmitted will be a value equal to the key down code plus 40 hex. The key code associated with key code '0' (0x30) is pressed, the release code is 'p' (0x70). In RS - 232 polled mode or via the I<sup>2</sup>C interface, these codes are available in the same manner as keypresses without auto repeat; however, the user should be careful to ensure that the poll rate is high enough so that simulated key repeats are avoided after the release of the key but before the next poll.

#### Physical Layout:

The returned key codes are as follows, but note that your keypad may be laid out in a different pattern. If this is the case, the user will need to interpret the key codes differently. The diagram 1 shows the logical layout (row 1, column 1 in upper left). The connector for the keypad is a 10 pin .1" spacing male header. Pin 1 is indicated on the connector layout diagram. Pins 1 through 5 are columns and pins 6 through 10 are row. The keypad is scanned whenever a key is pressed. There is no continuous key scan. This means that key presses are dealt with immediately without any appreciable latency. This also prevents electrical noise which is often caused by continuous key scans.

Diagram A

		<i>COLUMNS</i>				
		1	2	3	4	5
<i>R O W S</i>	1	A	B	C	D	E
	2	F	G	H	I	J
	3	K	L	M	N	O
	4	P	Q	R	S	T
	5	U	V	W	X	Y

***Keypad Connector***

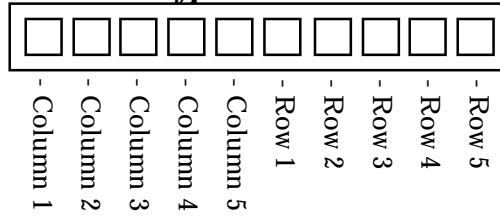

## LK204-25 Command Set

### Write Text

This section of the manual allows the user to send commands to the LK to alter the appearance or behavior of the display. To utilize a command, the user must send a command prefix followed by the command in the format described in this portion of the manual. Any characters sent without a command prefix will be interpreted as text and will be displayed on the module at the current cursor position. The current cursor position will be incremented for each character received. Please note that unless line wrap is turned on, the text will follow the memory map of the module.

The command set discusses in detail what the LK's capabilities of and how to execute each command. The basic format of all the commands listed in this segment that do not require parameters is:  
< command prefix> < command>

For commands that do require parameters however the format is as follows:  
< command prefix> < command> [< parameter> < parameter> .....]

### Basic Commands

All commands are prefixed by the command 0xFE, Hex FE, Decimal 254

#### Auto Repeat Mode On

ASCII '~', Hex 7E, Decimal 126  
Syntax 0xFE 0x7E

To turn auto repeat on and select mode, send a command prefix followed by the character '~', followed by either 0x00 or 0x01:

- = 0: 200ms typematic rate
  - = 1: Key down / Key up codes are sent
- In either case, auto repeat is turned on.  
Please see details in Keypad Interface section.

#### Auto Repeat Mode Off

ASCII '^', Hex 60 Decimal 96  
Syntax 0xFE 0x60

To turn auto repeat off, send a command prefix followed by the character '^'.

#### Auto Line Wrap On

ASCII 'C', Hex 43, Decimal 67  
Syntax 0xFE 0x43

This command enables the automatic line wrap function. Transmitted characters which overrun the width of the display will automatically wrap to the next line. The bottom line wraps to line 1 of the display. To carry out this command the user must send a command prefix followed the character 'C'.

#### Auto Line Wrap Off

ASCII 'D', Hex 44, Decimal 68  
Syntax 0xFE 0x44

This command disables the automatic line wrapping function. To turn off the the auto line wrapping, send a command prefix followed by the character 'D'.

**Auto Scroll On**

ASCII 'Q', Hex 51, Decimal 81  
Syntax 0xFE 0x51

To turn the automatic line scrolling on, send a command prefix followed by the character 'Q'. In combination with the "Auto Line Wrap" command the text will automatically wrap and scroll up.

Note: "Auto Line Wrap" must be enabled for "Auto Scroll" to work properly.

**Auto Scroll Off**

ASCII 'R', Hex 52, Decimal 82  
Syntax 0xFE 0x82

To turn the automatic line scrolling off, send a command prefix followed by the character 'R'.

**Auto Transmit Keypresses On**

ASCII 'A', Hex 41, Decimal 65  
Syntax 0xFE 0x41

To activate the automatic transmission of keypresses, send a command prefix followed by the character 'A'. In this mode, all keypresses are sent immediately to the host system without the use of poll keypad command. This is the default mode on power up.

**Auto Transmit Keypresses Off**

ASCII 'O', Hex 4F, Decimal 79  
Syntax 0xFE 0x4F

To disable the automatic transmission of keypresses, send a command prefix followed by the character 'O'. In this mode, up to 10 keypresses are buffered until the unit is polled by the host system via the poll keypad command.

**Poll Keypad**

ASCII '&', Hex 26, Decimal 38  
Syntax 0xFE 0x26

To return any unbuffered keypresses via the RS - 232 interface, send a command prefix followed by the character '&' and then set up the host system to receive the key codes. When a keypad module receives this command it will immediately return any unbuffered keypresses which may have not been read already. If there is more than one keypress buffered, then the high order bit of this returned keycode will be set. If this is the only buffered keypress, then the high order bit will be cleared. If there are no buffered keypresses, then the returned code will be 0x00.

**Enter Buffer Return Status Mode**

ASCII ':', Hex 3A, Decimal 58  
Syntax 0xFE 0x3A < almost full > < almost empty >

To enter buffer return status mode, send a command prefix followed by the character ':'. The module will now wait for the two bytes which define the parameters: Where < almost full > is the number of bytes that will be left in the buffer when the unit sends a "buffer is almost full" message to the host system, and where < almost empty > is the number of unprocessed bytes that will be left in the buffer when the unit sends a "buffer is almost empty" message.

Entering this mode tells the host system when the buffer of the display is almost full or almost empty. When the data being sent to the module reaches the user defined value of almost full, the module will relay the message 0xFE to the host system. The module will also relay this message for every byte that overruns the limit defined by the value for . When the buffer is almost empty the module will then relate back to the host system the message 0xFF, this informs the host system that the buffer is almost empty.

Whether the user is in 'Buffer Return Status Mode' or not, the module will ignore display or command bytes which would overrun the buffer. While in 'Buffer Return Status Mode' the unit will return 0xFE when buffer is almost full even though it may have already thrown rejected data away.

When using this command in an application, selection of the value for the buffer almost full should be considered very carefully. This is a critical aspect of using this command to its full potential. When using a host system or PC which contains a FIFO, the user should set the value of equal to or greater than the size of the FIFO. The reason for this is that the FIFO may be full when the host system receives 0xFE. In the case of 16550 UART the size at its maximum is 16, therefore the value of should be set to 16 or greater.

### **Exit Buffer Return Status Mode**

ASCII ';', Hex 3B, Decimal 59

Syntax 0xFE 0x3B

The command allows the user exit buffer return status mode.

### **Backlight On**

ASCII 'B', Hex 42, Decimal 66

Syntax 0xFE 0x42< number of minutes>

To turn the backlight on, send a command prefix followed by the character 'B' and the number of minutes for the backlight to remain on. If < minutes> is sent as zero then the backlight will remain on indefinitely. The maximum value for < minutes> is 100. Example:

< command prefix>	0xFE
< command>	0x42
< minutes>	0 to 100

### **Backlight Off**

ASCII 'F', Hex 46, Decimal 70

Syntax 0xFE 0x46

To turn the backlight off, send a command prefix followed by the character 'F'.

### **Clear Display**

ASCII 'X', Hex 58, Decimal 88

Syntax 0xFE 0x58

This command clears any text and graphics off the display. To clear the display, send a command prefix followed the character 'X'.

### **Clear Key Buffer**

ASCII 'E', Hex 45, Decimal 69

Syntax 0xFE 0x45

This command clears any unread keypresses. In a menuing application, if the user presses a key which changes the menu context, any following key presses may be inaccurate and can be cleared out of the buffer between menu changes to prevent jumping around the menu tree. It may also be used to, in effect, reset the keypad in case the application resets for whatever reason. To execute this command, send a command prefix followed by the character 'E'.

**Contrast**

ASCII 'P', Hex 50, Decimal 80

Syntax 0xFE 0x80< hex value defining contrast>

This command allows you to set the display contrast to a level between 0(light) and 256(dark). To execute this command, send a command prefix followed by the character 'P' and a hex value between 0x00 and 0xFF. Different displays and lighting conditions will affect the actual value used. Different modules have different power up contrast settings. Example:

< command prefix>	0xFE
< command>	0x50
< hex value>	0x00 to 0xFF (level of contrast)

**Cursor On**

ASCII 'J', Hex 4A, Decimal 74

Syntax 0xFE 0x4A

To turn the cursor on at the current position, send a command prefix followed by the character 'J'. Note cursor is on by default at power up.

**Cursor Off**

ASCII 'K', Hex 4B, Decimal 75

Syntax 0xFE 0x4B

To turn the cursor off at the current position , send a command prefix followed by the character 'K'.

**Cursor Left**

ASCII 'L', Hex 4C, Decimal 76

Syntax 0xFE 0x4C

To move the cursor one space to the left of current position, send a command prefix followed by the character 'L'.

**Cursor Right**

ASCII 'M', Hex 4D, Decimal 77

Syntax 0xFE x04D

To move the cursor one space to the right of the current position, send a command prefix followed by the character 'M'.

**Cursor Blink On**

ASCII 'S', Hex 53, Decimal 83

Syntax 0xFE 0x53

To turn on the blinking cursor at the current position, send a command prefix followed by the character 'S'. Please note that the blinking cursor is on by default at power up.

**Cursor Blink Off**

ASCII 'T', Hex 54, Decimal 84

Syntax 0xFE 0x54

To turn off the blinking cursor at the current position send a command prefix followed by the character 'T'.

### Set Debounce Time

ASCII 'U', Hex 55, Decimal 85

Syntax 0xFE 0x55 < number to define debounce time >

To set the time between key press and key read, send a command prefix followed by the character 'U' and a number to define the debounce time. All key types with the exception of latched piezo switches will "bounce" for a varying time, depending on their physical characteristics. The default debounce time for the module is about 65mS, which is adequate for most membrane keypads. This time equates to a setting of 8 using this command as there is a debounce time resolution of 8192 microseconds.

### Create Custom Character

ASCII 'N', Hex 4E, Decimal 78

Syntax 0xFE 0x4E < character between 0x00 and 0x07 > < 8 bytes >

This command creates a custom character. For the LK204-25 the user can have up to eight custom characters. To execute this command, send a command prefix followed by the character 'N'. The display will now await the number which identifies the custom character. This number must be between 0x00 and 0x07. When the module determines what character it's working on, then the user must send 8 bytes which define the display character. See the diagram below for an explanation of the display character structure.

**Diagram A**

MSB								LSB	
*	*	*	1	2	3	4	5	Data Byte 1	
*	*	*	6	7	8	9	10	Data Byte 2	
*	*	*	11	12	13	14	15	Data Byte 3	
*	*	*	16	17	18	19	20	Data Byte 4	
*	*	*	21	22	23	24	25	Data Byte 5	
*	*	*	26	27	28	29	30	Data Byte 6	
*	*	*	31	32	33	34	35	Data Byte 7	
*	*	*	36	37	38	39	40	Data Byte 8	

**Pixel Layout of Display Characters**

1	2	3	4	5
6	7	8	9	10
11	12	13	14	15
16	17	18	19	20
21	22	23	24	25
26	27	28	29	30
31	32	33	34	35
36	37	38	39	40
Cursor Line				

### General Purpose Output On

ASCII 'V', Hex 56, Decimal 86

Syntax 0xFE 0x56 < hex number corresponding to output >

To turn a general output purpose on, send a command prefix followed by the character 'V' and hex number which corresponds to the output which will be turned on. To turn on output five, the sequence would be:

< command prefix >	0xFE
< command >	0x56
< hex number corresponding to output >	05H

### **General Purpose Output Off**

ASCII 'W', Hex 57, Decimal 87

Syntax 0xFE 0x57 < hex number corresponding to output >

To turn a general output purpose off, send a command prefix followed by the character 'W' and a hex number which corresponds to the output which will be turned off.

### **Go To Position**

ASCII 'G', Hex 47, Decimal 71

Syntax 0xFE 0x47 < column number > < row number >

To set the current cursor position, send a command prefix followed by the character 'G' and two values defining the column and row of the desired cursor position.

### **Go To Top Left**

ASCII 'H', Hex 48, Decimal 72

Syntax 0xFE 0x48

This command resets the current cursor position to the top left of the LK screen. To execute this command send a command prefix followed by character 'H'.

### **Initialize Large Digits**

ASCII 'n', Hex 6E, Decimal 110

Syntax 0xFE 0x6E

Before any large digits may be created, this command must be executed. It only needs to be sent once to initialize the custom characters for large digits. Due to the fact large digits use pre-determined custom characters, no user custom characters may be displayed or created while digits are in use.

### **Place Large Digit**

ASCII '#', Hex 23, Decimal 35

Syntax 0xFE 0x35 < column number > < digit number >

This command allows the creation of large digits on the LK screen. To execute this command the user must send a command prefix followed by the character '#' and the column number where the digit is to be placed. Then the user must enter the number of the large digit which is required in hexadecimal. Numbers of almost full display height may be placed along side regular text on four row displays. The column number has a maximum value which is less than the display width because the digits are all three columns wide. The module must be initialized for large digit creation before large digits may be placed. If regular text and large digits are mixed on one screen, the user should always set the display cursor position before placing regular text because the creation of a large digit will leave the cursor position to the bottom right of the large digit and not at the last regular text write position. The format for this command is as follows:

< command prefix >	0xFE
< command >	0x23
< column number >	0x01 to 0x12 (1 to 18 for a 20 column display)
< digit number >	0x00 to 0x09 (numbers 0 to 9)

### **Initialize Horizontal Bar Graph**

ASCII 'h', Hex 68, Decimal 104

Syntax 0xFE 0x68

Before any horizontal bar graphs may be created, this command must be executed. It only needs to be sent once to initialize the custom characters for bar graph creation. Due to the fact bar graphs use custom characters, no user custom characters may be displayed or created while bar graphs are in use.

### **Make Horizontal Bar Graph**

ASCII '|', Hex 7C, Decimal 124

Syntax 0xFE 0x7C < column number > < row number > < direction > < bar length >

This command places a horizontal bar graph at the specified column and row with the specified width. The format of the command is as follows:

< command prefix >	0xFE
< command >	0x7C
< column number >	0x01 to 0x14 for a twenty column display
< row number >	0x01 to 0x04 for a four line display
< direction >	0 for left to right, 1 for right to left
< bar length >	0x00 to 0x64 (0 to 100) for a twenty column display

Bar length is in pixel widths. On a twenty column display the maximum bar graph width is one hundred (if the bar graph starts at the edge). This is due to the fact that each of the twenty columns on the display are five pixels wide. The width of the space between columns is not taken into account.

### **Initialize Thick Vertical Bar Graph**

ASCII 'v', Hex 76, Decimal 118

Syntax 0xFE 0x76

Before any thick vertical bar graphs may be created, this command must be executed. It only needs to be sent once to initialize the custom characters required for bar graph creation. Bar graphs use custom characters, therefore no user custom characters may be displayed or created while bar graphs are in use.

### **Initialize Thin Bar Vertical Graph**

ASCII 's', Hex 73, Decimal 115

Syntax 0xFE 0x73

This command is executed in exactly the same manner as the 'Initialize Thick Bar Graph' command.

### **Make Vertical Bar Graph**

ASCII '=', Hex 3D, Decimal 61

Syntax 0xFE 0x3D < column number > < bar length >

This command places a bar graph at the specified column with the specified height. The style of the vertical bar graph whether it be thick or thin is selected by the initialize vertical bar graph command. If thick bar graphs are preferred, the 'v' command should be sent to initialize the bar graph. If a thin vertical bar graph is desired, the 's' command should be sent to initialize the bar graph. The format for the command is as follows:

< command prefix >	0xFE
< command >	0x3D
< column number >	0x01 to 0x14 for an twenty column display
< bar length >	0x00 to 0x20 (1 to 32) for a four line display.

Bar height is in pixel widths. On a four line display the maximum bar graph height is thirty-two, this is because each of the lines in the display are eight pixels high. The width of the space between the lines is not taken into account.

**Note: Large Digits may not be used with bar graphs. Vertical bar graphs may not be used with horizontal bar graphs, and thick bar graphs may not be used with thin bar graphs. This is because all these functions make use of the same "custom character" spaces. As a result, custom characters are also unavailable while any of these functions are in use.**

### LK Character Font Chart

					D7	0	0	0	0	0	0	0	0	1	1	1	1	1	1	1	1	
					D6	0	0	0	0	1	1	1	1	0	0	0	0	1	1	1	1	
					D5	0	0	1	1	0	0	1	1	0	0	1	1	0	0	1	1	
					D4	0	1	0	1	0	1	0	1	0	1	0	1	0	1	0	1	
D3	D2	D1	D0		0	1	2	3	4	5	6	7	8	9	A	B	C	D	E	F		
0	0	0	0	0	0				0	0	P	`	P				—	9	E	0	P	
0	0	0	1	1	1			!	1	A	Q	a	a				.	7	†	4	ä	9
0	0	1	0	2	2			"	2	B	R	b	r				7	4	×	B	B	
0	0	1	1	3	3			#	3	C	S	c	s				7	0	T	E	E	∞
0	1	0	0	4	4			\$	4	D	T	d	t				\	I	†	†	H	o
0	1	0	1	5	5			%	5	E	U	e	u				.	†	†	1	e	ü
0	1	1	0	6	6			&	6	F	V	f	v				7	0	2	3	A	Σ
0	1	1	1	7	7			'	7	G	W	g	w				7	†	†	7	g	π
1	0	0	0	8	8			<	8	H	X	h	x				4	0	†	U	J	×
1	0	0	1	9	9			>	9	I	Y	i	y				9	T	U	U	Y	W
1	0	1	0	A	A			*	A	J	Z	j	z				±	0	†	U	J	†
1	0	1	1	B	B			+	B	K	L	k	l				†	†	E	0	†	†
1	1	0	0	C	C			,	C	L	#	l	l				†	†	†	†	†	†
1	1	0	1	D	D			—	D	=	M	I	m	›			±	†	†	†	†	†
1	1	1	0	E	E			.	E	>	N	^	n	→			3	†	†	†	†	†
1	1	1	1	F	F			/	F	?	0	_	o	←			w	U	†	†	ö	■

## Specifications

### Environmental Specifications

	<b>Standard Temp.</b>	<b>Extended Temp.</b>
<b>Operating Temperature</b>	0° to +50° C	-20° to +70° C
<b>Storage Temperature</b>	-20° to +70° C	-40° to +85° C
<b>Operating Relative Humidity</b>	90% max non-condensing	

### Electrical Specifications

<b>Supply Voltage</b>	4.75 - 5.25 Vdc (optional 7 - 15Vdc)
<b>Supply Current</b>	10mA typical
<b>Backlight Supply Current</b>	90mA typical

### Optical Characteristics

<b>Number of characters</b>	80 (20 Characters x 4 Lines)
<b>Matrix format</b>	5 x 7 with underline
<b>Display area</b>	73.60 x 25.20 mm (XxY)
<b>Character size</b>	2.95 x 4.75 mm (XxY), not including underline
<b>Character pitch</b>	3.55 mm
<b>Line pitch</b>	5.35 mm
<b>Dot size</b>	0.55 x 0.55 mm (XxY)
<b>Dot pitch</b>	0.60 x 0.60 mm (XxY)
<b>LED Backlight life</b>	100,000 hours typical
<b>Color of illumination</b>	Yellow green

## Appendix

Hex numbers are specified in C language convention as 0xUL - where U is the upper nibble and L is the lower nibble. Eg: 0xFE is 1111 1110 in binary. This is equivalent to ULH or ULh as in the binary number

1111	1110
upper	lower
nibble	nibble

.....which would be FEH or FEh

LK204-25

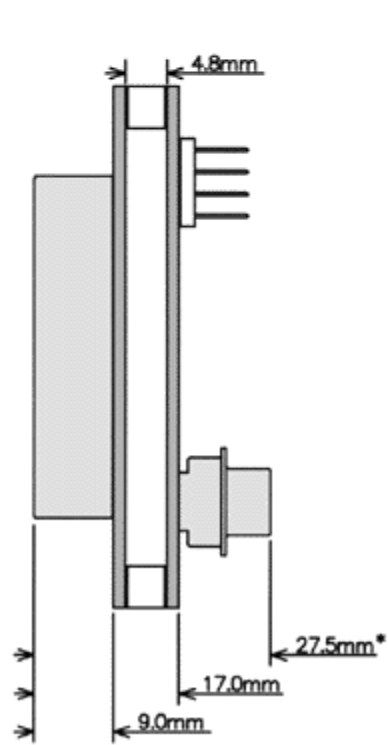
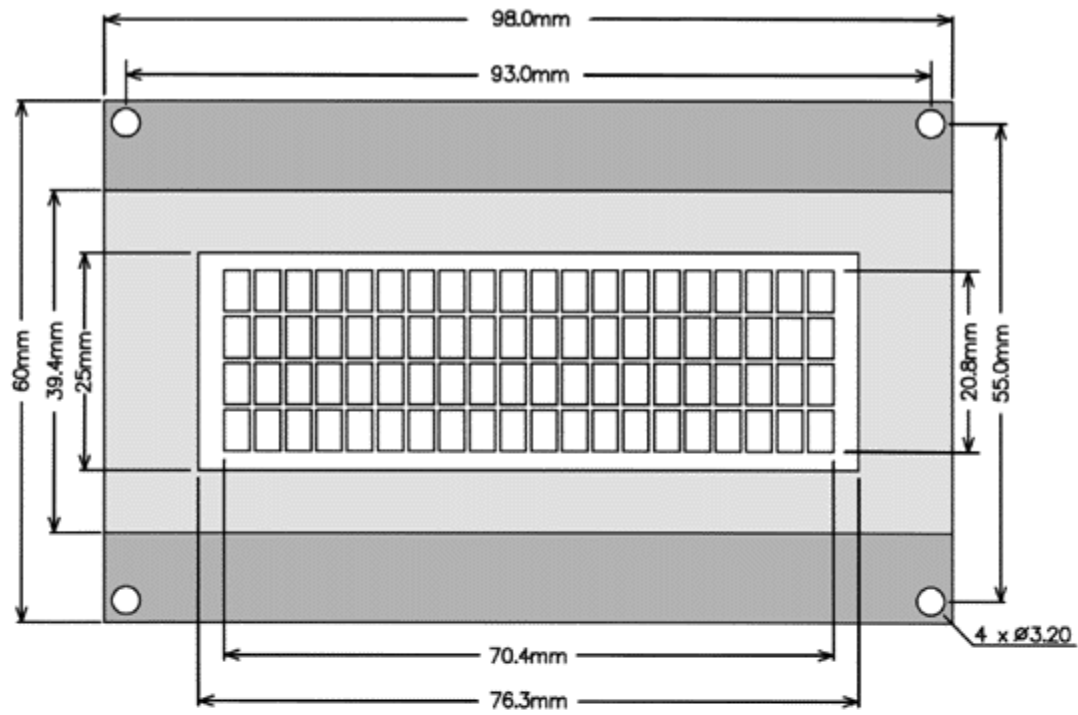

\* Max depth 21.0mm without connectors

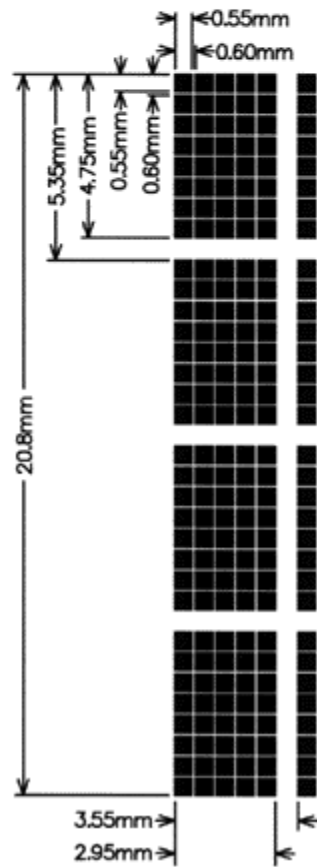

## **NORTH AMERICA**

### CANADA

#### **HVW Technologies**

Suite 473, 300 - 8120 Beddington Blvd. N.W.  
Calgary, Alberta T3K 2A8 Canada  
Telephone: + 1 403 730 8603  
Facsimile: + 1 403 730 8903  
Email: [info@hvwtech.com](mailto:info@hvwtech.com)  
WWW: <http://www.hvwtech.com/>

#### **Tri-M Systems Inc.**

6-1301 Ketch Court  
Coquitlam, BC V3K 6X7 Canada  
Toll Free Telephone: 1 800 665 5600  
Alternate Telephone: + 1 604 527 1100  
Facsimile: + 1 604 527 1110  
Email: [info@tri-m.com](mailto:info@tri-m.com)  
WWW: <http://www.tri-m.com/>

### UNITED STATES

#### **EMJ Embedded Systems**

Suite 100-1434 Farrington Road  
Apex, North Carolina 27502 USA  
Toll Free Telephone: 1 800 436 5872  
Facsimile: + 1 919 363 4425  
Email: [sales@emjembedded.com](mailto:sales@emjembedded.com)  
WWW: <http://www.emjembedded.com/>

#### **Jameco Electronic Components**

1355 Shoreway Road  
Belmont, California 94002-4100 US  
Toll Free Telephone: 1 800 831 4242  
Toll Free Facsimile: 1 800 237 6948  
Email: [sales@jameco.com](mailto:sales@jameco.com)  
WWW: <http://www.jameco.com/>

**Note:** Currently only carries LCD2041, LK204-25

#### **Linux Central**

Suite T2 37060 Garfield  
Clinton Township, Michigan 48036 USA  
Telephone: + 1 810 226 8200  
Toll Free Telephone: 1 877 LINUX CD (546 8923)  
Facsimile: + 1 810 226 8600  
Email: [sales@linuxcentral.com](mailto:sales@linuxcentral.com)  
WWW: <http://linuxcentral.com/>

## **EUROPE**

### AUSTRIA

#### **MEGATON Ges.m.b.H.**

Franz-Schubert-Gasse 12, A-2372 GIESSHÜBL  
Telephone : + 43 0 2236 43179  
Facsimile : + 43 0 2236 4317921  
Email: [oesterreich@elektronikladen.de](mailto:oesterreich@elektronikladen.de)

### FINLAND

#### **Symmetric Oy**

Maria Jotunin Tie 11  
Helinski, Finland 00400  
Telephone: + 358 9 5885 322  
Facsimile: + 358 9 5885 578  
Email: [symmetric@symmetric.fi](mailto:symmetric@symmetric.fi)  
WWW: <http://www.symmetric.fi/>

### GERMANY

#### **Elektronikladen Mikrocomputer GmbH**

Offices throughout Germany  
Telephone : + 49 0 5232 8171  
Facsimile : + 49 0 5232 86197  
Email: [sales@elektronikladen.de](mailto:sales@elektronikladen.de)  
WWW: <http://www.elektronikladen.de/>

### THE NETHERLANDS

#### **Antratek Electronics**

Kanaalweg 33,  
NL-2903LR Capelle aan den IJssel, The Netherlands  
Telephone : + 31 10 4504949  
Facsimile : + 31 10 4514955  
Email: [info@antratek.nl](mailto:info@antratek.nl)  
WWW: <http://www.antratek.nl>

### ITALY

#### **QuadriviumNET**

Via Circonvalazione Sud, 76  
33033 Codriopo, Udine, Italy  
Telephone : + 39 0 432 906062  
Facsimile : + 39 0 432 901514  
Email: [info@qnet.it](mailto:info@qnet.it)  
WWW: <http://www.qnet.it/>

## SCANDINAVIA

### **Lawicel**

Klubbgatan 3  
SE-282 32 Tyringe, Sweden  
Telephone: + 46 0 451 598 77  
Facsimile: + 46 0 451 598 78  
Email: info@lawicel.com  
WWW: <http://www.lawicel.com>

### **Lilla Fabriken**

Box 1003  
SE-172 21 Sundbyberg, Sweden  
Telephone: + 46 8 287 286  
Facsimile: + 46 8 288 802  
Email: info@lillfab.se  
WWW: <http://www.lillfab.se>

## SWITZERLAND

### **Bernhard Elektronik**

Aarauer Str. 20,  
CH-5734 Reinach AG  
Telephone : + 41 0 62 7716944  
Facsimile : + 41 0 62 7716944  
Email : schweiz@elektronikladen.de

## MIDDLE EAST

### ISRAEL

### **Alpha Terminals & Printers Ltd.**

7 Ha'Mifalm St.  
Petach - Tikva, Israel 49250  
Telephone: + 972 3 9214422  
Facsimile: + 972 3 9219966  
Email: alpha99@ibm.net

## AUSTRALIA

### AUSTRALIA

### **Alfa-Tek**

Unit 7, 42 - 50 Stud Road  
Bayswater, Victoria, Australia, 3111  
Telephone: + 61 39 720 5344  
Facsimile: + 61 39 720 5268  
Email: will@alfatek.com.au  
WWW: <http://www.alfatek.com.au/>

## ASIA

### INDIA

### **AL Systems**

105, 3rd Street,  
Tatabad, Coimbatore - 641012  
Tamil Nadu, India  
Telephone: +91-422-233166, 493960  
Facsimile: +91-422-230958, 213849  
Email: also@vsnl.com  
WWW:[http://business.vsnl.com/al\\_systems](http://business.vsnl.com/al_systems)

## AFRICA

### EGYPT

### **AmGroup 13**

Sheraton Heliopolis  
Zone 8, Cairo EGYPT  
Email: amgrou@link.com.eg

